

N-Channel Enhancement-Mode MOSFET

V_{DS} 30V $R_{DS(ON)}$ $8m\Omega$ I_D 70A

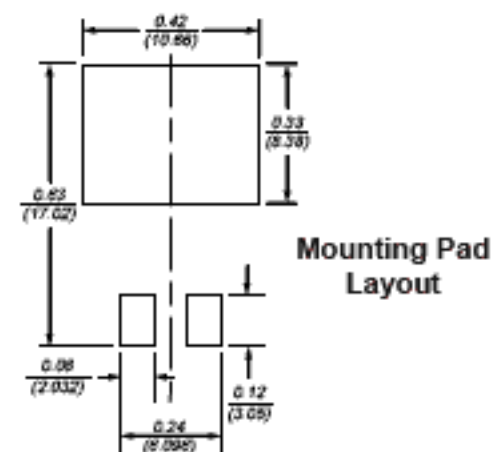

TO-263AB

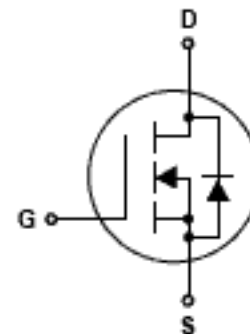
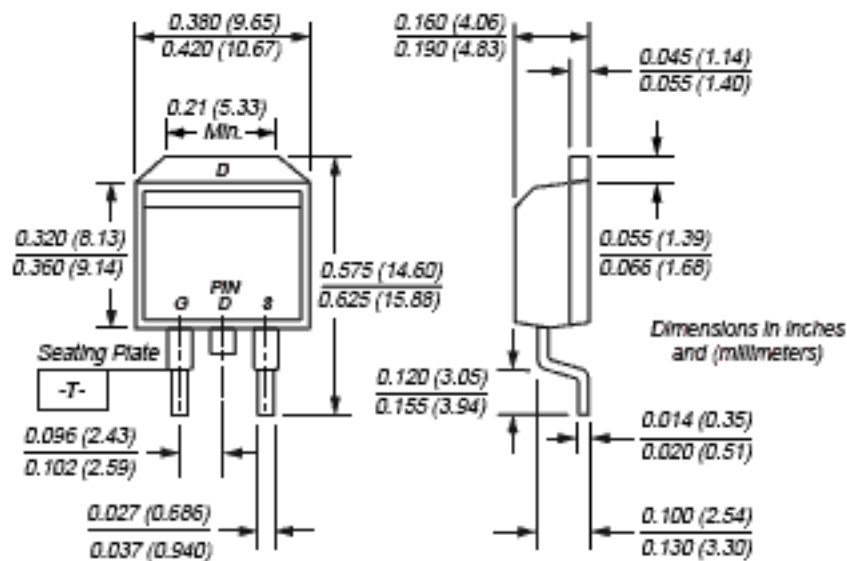

Mechanical Data

Case: JEDEC TO-263 molded plastic body

Terminals: Leads solderable per MIL-STD-750, Method 2028

High temperature soldering guaranteed:
250°C/10 seconds at terminals

Mounting Position: Any Weight: 1.3g

Features

- Advanced Trench Process Technology
- High Density Cell Design for Ultra Low On-Resistance
- Specially Designed for Low Voltage DC/DC Converters
- Fast Switching for High Efficiency

Maximum Ratings and Thermal Characteristics ($T_C = 25^\circ\text{C}$ unless otherwise noted)

Parameter	Symbol	Limit	Unit
Drain-Source Voltage	V_{DS}	30	V
Gate-Source Voltage	V_{GS}	± 20	
Continuous Drain Current ⁽¹⁾	I_D	70	A
Pulsed Drain Current	I_{DM}	200	
Maximum Power Dissipation	P_D	62.5 25	W
		$T_C = 25^\circ\text{C}$ $T_C = 100^\circ\text{C}$	
Operating Junction and Storage Temperature Range	T_J, T_{stg}	-55 to 150	$^\circ\text{C}$
Lead Temperature (1/8" from case for 5 sec.)	T_L	275	$^\circ\text{C}$
Junction-to-Case Thermal Resistance	$R_{\theta JC}$	2.0	$^\circ\text{C/W}$
Junction-to-Ambient Thermal Resistance ⁽²⁾	$R_{\theta JA}$	40	$^\circ\text{C/W}$

Notes: (1) Maximum DC current limited by the package
(2) 1-in² 2oz. Cu PCB mounted

N-Channel Enhancement-Mode MOSFET

Electrical Characteristics ($T_J = 25^\circ\text{C}$ unless otherwise noted)

Parameter	Symbol	Test Condition	Min	Typ	Max	Unit
Static						
Drain-Source Breakdown Voltage	BV_{DSS}	$V_{GS} = 0V, I_D = 250\mu A$	30	—	—	V
Gate Threshold Voltage	$V_{GS(th)}$	$V_{DS} = V_{GS}, I_D = 250\mu A$	1.0	—	3.0	V
Gate-Body Leakage	I_{GSS}	$V_{DS} = 0V, V_{GS} = \pm 20V$	—	—	± 100	nA
Zero Gate Voltage Drain Current	I_{DSS}	$V_{DS} = 30V, V_{GS} = 0V$	—	—	1	μA
On-State Drain Current ⁽¹⁾	$I_{D(on)}$	$V_{DS} \geq 5V, V_{GS} = 10V$	70	—	—	A
Drain-Source On-State Resistance ⁽¹⁾	$R_{DS(on)}$	$V_{GS} = 10V, I_D = 35A$	—	8	8	m Ω
		$V_{GS} = 4.5V, I_D = 30A$	—	9	11	
Forward Transconductance ⁽¹⁾	g_{fs}	$V_{DS} = 15V, I_D = 35A$	—	61	—	S
Dynamic						
Total Gate Charge	Q_g	$V_{DS}=15V, V_{GS}=5V, I_D=35A$	—	34	48	nC
		$V_{DS} = 15V, V_{GS} = 10V$ $I_D = 35A$	—	63	95	
			—	11	—	
Gate-Source Charge	Q_{gs}	$V_{DS} = 15V, V_{GS} = 10V$ $I_D = 35A$	—	11	—	nC
Gate-Drain Charge	Q_{gd}		—	11	—	
Turn-On Delay Time	$t_{d(on)}$	$V_{DD} = 15V, R_L = 15\Omega$ $I_D \approx 1A, V_{GEN} = 10V$ $R_G = 6\Omega$	—	9	14	ns
Rise Time	t_r		—	9	14	
Turn-Off Delay Time	$t_{d(off)}$		—	100	167	
Fall Time	t_f		—	31	62	
Input Capacitance	C_{iss}	$V_{GS} = 0V$	—	3400	—	pF
Output Capacitance	C_{oss}	$V_{DS} = 15V$	—	618	—	
Reverse Transfer Capacitance	C_{rss}	$f = 1.0\text{MHz}$	—	300	—	
Source-Drain Diode						
Max Diode Forward Current	I_S	—	—	—	35	A
Diode Forward Voltage ⁽¹⁾	V_{SD}	$I_S = 35A, V_{GS} = 0V$	—	0.9	1.3	V

Note: (1) Pulse test; pulse width $\leq 300 \mu s$, duty cycle $\leq 2\%$

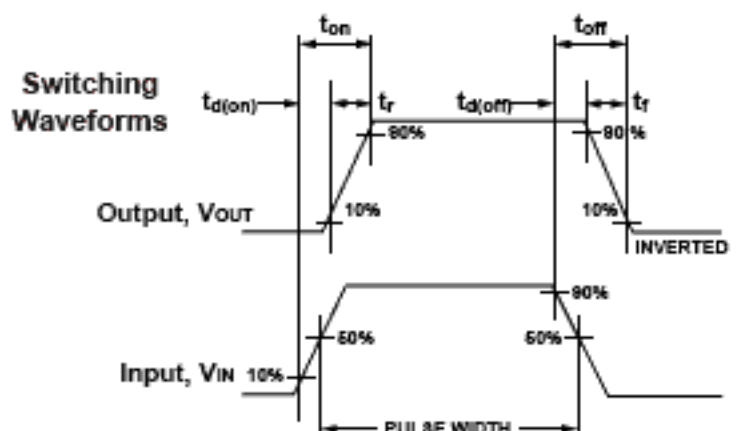
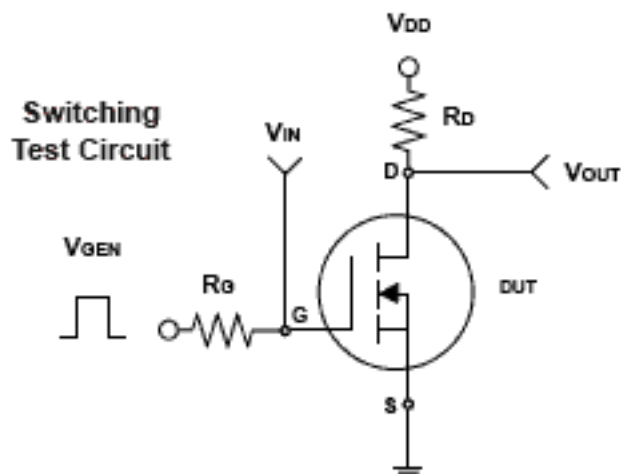

N-Channel Enhancement-Mode MOSFET

Ratings and Characteristic Curves ($T_A = 25^\circ\text{C}$ unless otherwise noted)

Fig. 1 – Output Characteristics

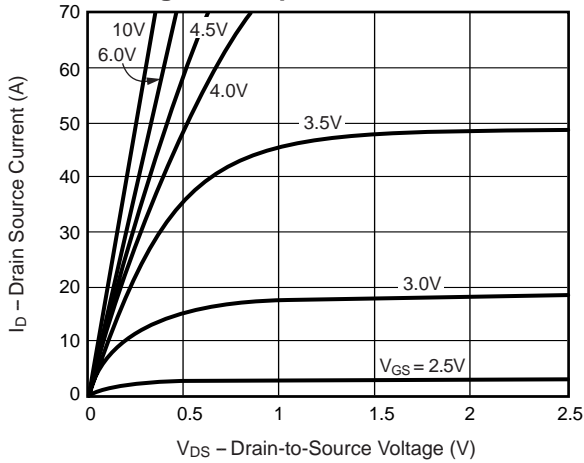

Fig. 2 – Transfer Characteristics

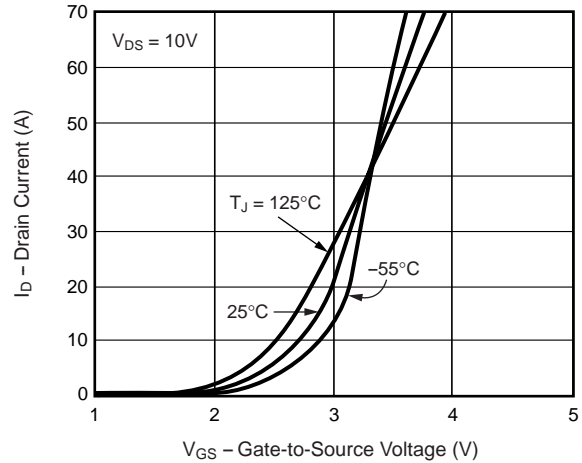

Fig. 3 – Threshold Voltage vs. Temperature

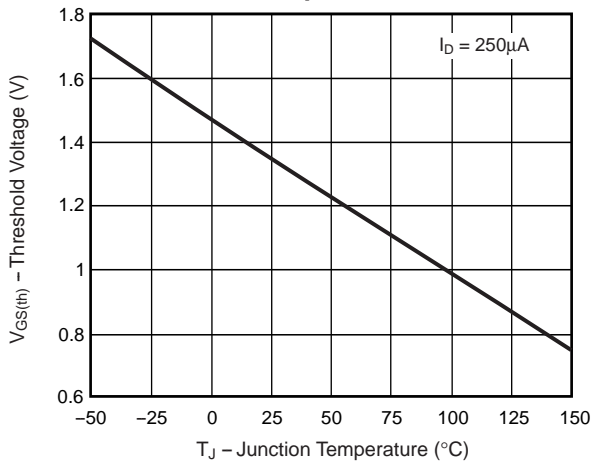

Fig. 4 – On-Resistance vs. Drain Current

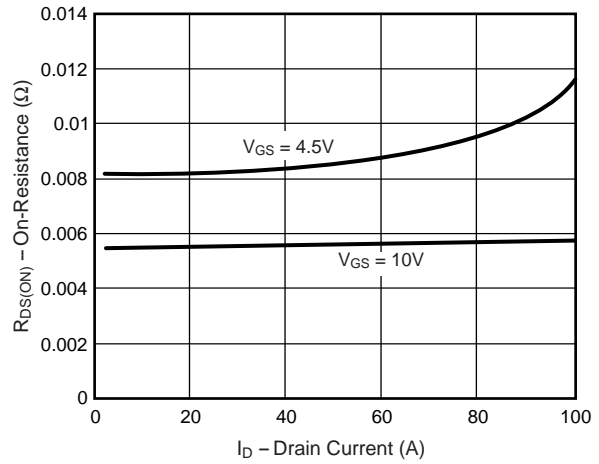
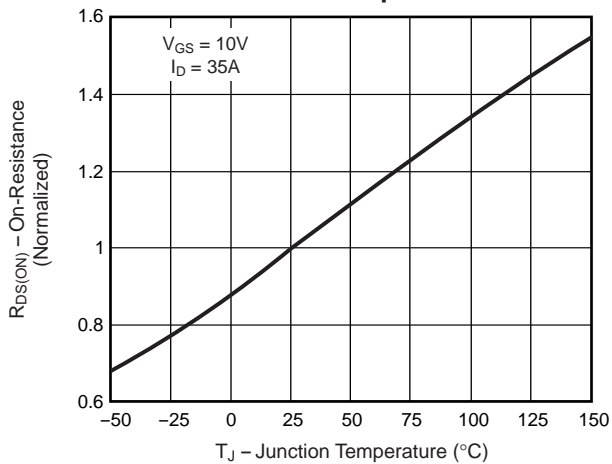

Fig. 5 – On-Resistance vs. Junction Temperature



N-Channel Enhancement-Mode MOSFET

Ratings and Characteristic Curves (T_A = 25°C unless otherwise noted)

Fig. 6 – On-Resistance vs. Gate-to-Source Voltage

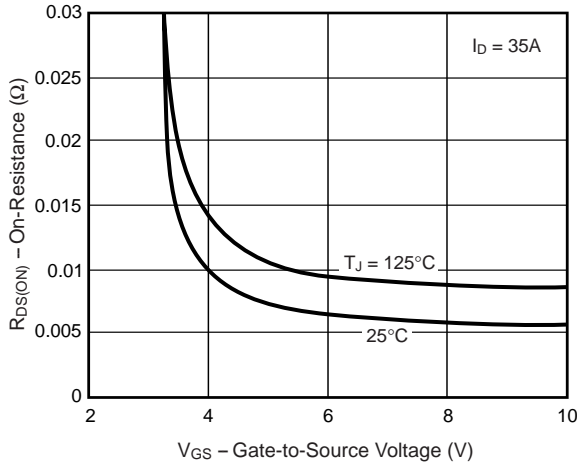

Fig. 7 – Gate Charge

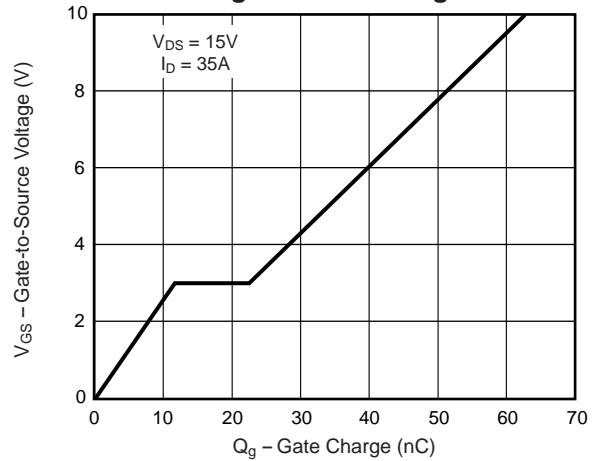

Fig. 8 – Capacitance

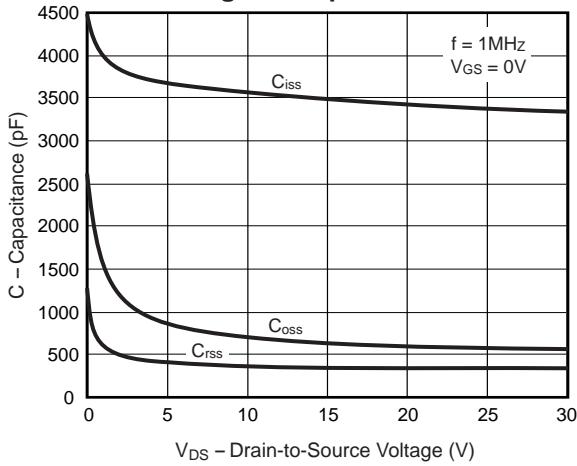
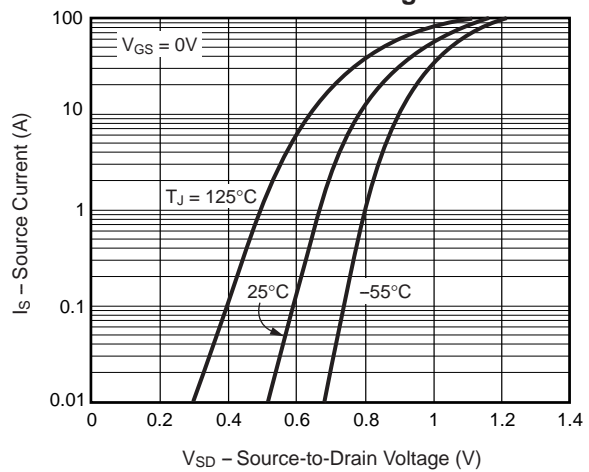

Fig. 9 – Source-Drain Diode Forward Voltage



N-Channel Enhancement-Mode MOSFET

Ratings and Characteristic Curves (T_A = 25°C unless otherwise noted)

Fig. 10 – Breakdown Voltage vs. Junction Temperature

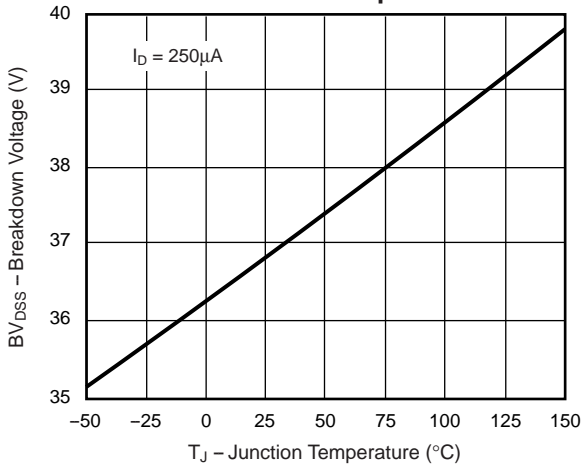

Fig. 11 – Thermal Impedance

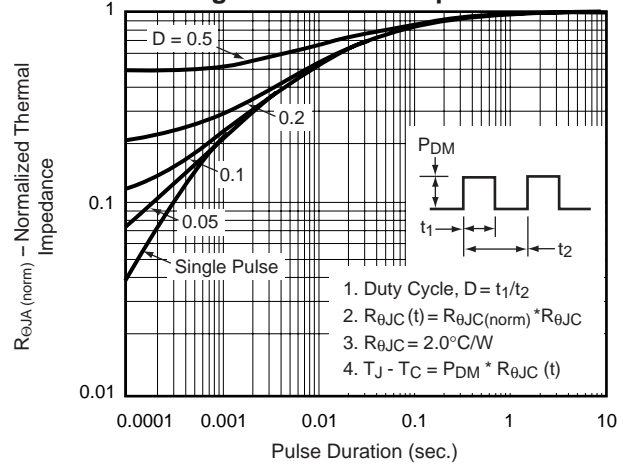

Fig. 12 – Power vs. Pulse Duration

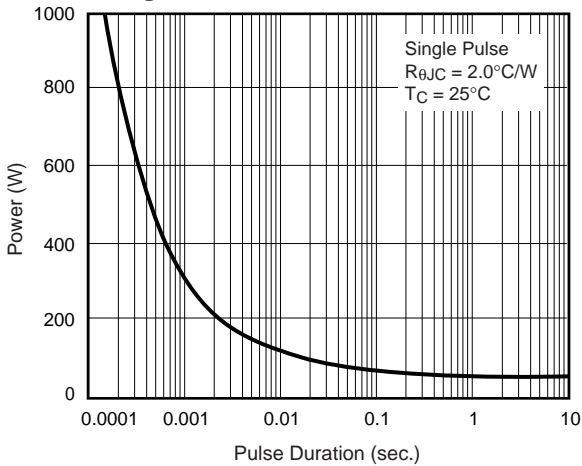
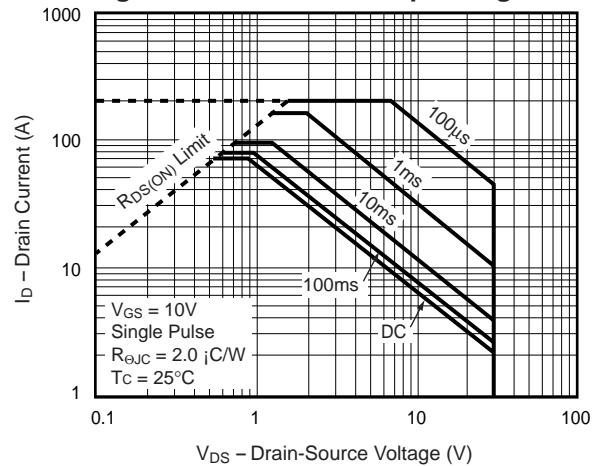

Fig. 13 – Maximum Safe Operating Area



This datasheet has been downloaded from:

www.DatasheetCatalog.com

Datasheets for electronic components.